

For compressors

Disassemblable  
Metal

### FEATURES

- Wide-angle flat spray; spray angle of 90° provides larger spray coverage.
- 3-piece structure; air spray volume can be adjusted by changing spray tips.
- Capable of steam spraying.

► Produces a flat spray pattern of air or steam.



Material: S303, B (brass)  
(Optional material: S316)  
Max. allowable temperature: 400°C (750°F) for S303  
200°C (390°F) for Brass



### DIMENSIONS

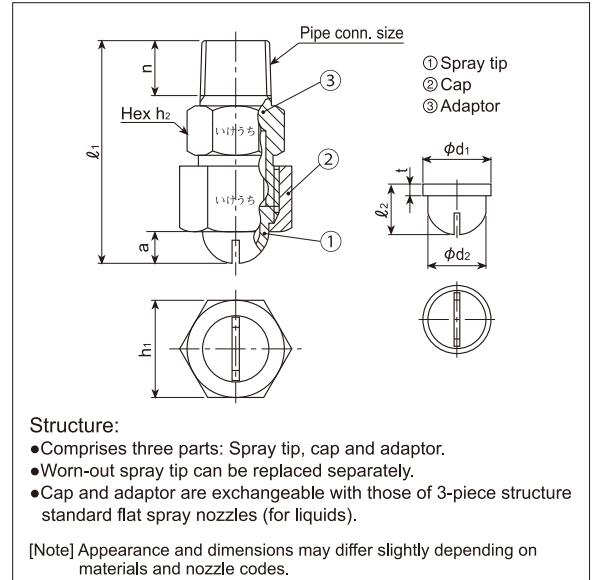

### [Complete nozzle]

Pipe connection size	Outer dimensions (mm)					Mass (g)	
	l <sub>1</sub>	h <sub>1</sub>	h <sub>2</sub>	a	n	S303	B
1/4M	43	19	17	6.5	10.5	44	47
3/8M	48.5	23	21	9.5	11	73	78

### [Spray tip]

Pipe connection size	Outer dimensions (mm)				Mass (g)	
	l <sub>2</sub>	φd <sub>1</sub>	φd <sub>2</sub>	t	S303	B
1/4M	11	14.5	12.5	2.5	4.7	5.0
3/8M	14	18	16	2.5	7.7	8.1

Spray angle code	Air capacity code	Pipe connection size		Air capacity (ℓ/min, Normal)						Steam capacity (kg/hr)					Free passage diameter (mm)	
		1/4M	3/8M	0.05 MPa	0.1 MPa	0.2 MPa	0.3 MPa	0.5 MPa	0.7 MPa	0.05 MPa	0.1 MPa	0.2 MPa	0.3 MPa	0.5 MPa		0.7 MPa
90°	150	○		55.7	77.6	116	154	230	307	2.62	3.56	5.27	6.97	10.3	13.7	0.2
	200	○		73.1	102	152	202	302	402	3.44	4.67	6.92	9.14	13.6	17.9	0.3
	250	○		90.5	126	188	250	374	498	4.26	5.78	8.57	11.3	16.8	22.2	0.4
	300	○		108	150	224	298	446	594	5.08	6.90	10.2	13.5	20.0	26.5	0.5
	350	○		125	175	261	346	518	690	5.90	8.00	11.9	15.7	23.2	30.7	0.6
	400	○		143	199	297	394	590	786	6.72	9.12	13.5	17.9	26.5	35.0	0.7
	450	○		160	223	333	443	662	882	7.54	10.2	15.2	20.0	29.7	39.3	0.8
	500	○		177	247	369	491	734	977	8.36	11.3	16.8	22.2	32.9	43.5	0.9
	550		○	199	278	414	551	823	1,096	9.38	12.7	18.8	24.9	36.9	48.8	0.6
	600		○	219	305	455	605	905	1,205	10.3	14.0	20.7	27.4	40.6	53.7	0.7
	650		○	235	328	489	650	972	1,295	11.1	15.0	22.3	29.4	43.6	57.7	0.8
	700		○	253	353	526	700	1,047	1,394	11.9	16.2	24.0	31.7	46.9	62.1	0.8
	750		○	272	380	566	753	1,126	1,500	12.8	17.4	25.8	34.1	50.5	66.8	0.9
	900		○	326	454	677	901	1,347	1,794	15.3	20.8	30.8	40.7	60.4	79.9	1.1
1130		○	406	566	844	1,122	1,678	2,235	19.1	25.9	38.4	50.8	75.2	99.5	1.4	

Standard pressure: 0.3MPa

### How to order

Please inquire or order for a specific nozzle using this coding system.

① Complete nozzle <Example> 1/4M VZ 150 S303

**1/4 M**   **VZ**   **150**   **S303**  
 Pipe conn. size   Air capacity code   Material  
 ■ 1/4M   ■ 150   ■ S303  
 ■ 3/8M   ■ 1130   ■ B (brass)

② Spray tip only <Example> 1/4VZ 150 S303

**1/4**   **VZ**   **150**   **S303**  
 Pipe conn. size   Air capacity code   Material  
 ■ 1/4   ■ 150   ■ S303  
 ■ 3/8   ■ 1130   ■ B (brass)