



UGELLI ASSIALI A GETTO PIATTO - SERIE OVK/OVKIR AXIAL-FEED VEE-JET NOZZLES – OVK/OVKIR SERIES

OV

CARATTERISTICHE

- Dimensioni ridotte per sfruttare al massimo lo spazio disponibile
- Filettature metriche da **M4**

CHARACTERISTICS

- Small overall dimensions to exploit to the utmost the available space
- Metric thread from **M4**

CODE STD.
MAT.

02 AISI 316
06 Ottone/Brass

APPLICAZIONI CONSIGLIATE

- Lavatrici e lavastoviglie industriali

TYPICAL APPLICATIONS

- Industrial washing and dishwashing machines



Tipo / Type OVK



Tipo / Type OVKIR

DATI OPERATIVI - OPERATIVE DATA

TIPO / TYPE OVK Dimensione raccordo / Thread dimension					CODICE PORTATA FLOW CODE	PORTATA / FLOW l/min										AMPIEZZA ANGOLO DI SPRUZZO SPRAY ANGLE WIDTH
IR	M4	M5	M6	M8		0,5 bar	1 bar	1,5 bar	2 bar	3 bar	4 bar	5 bar	7 bar	10 bar	15 bar	
▼	▼	▼	▼	▼	022	0,11	0,16	0,19	0,22	0,27	0,31	0,3	0,4	0,5	0,6	45° - 60° - 90° - 120°
▼	▼	▼	▼	▼	035	0,18	0,25	0,30	0,35	0,43	0,49	0,6	0,7	0,8	1,0	
▼	▼	▼	▼	▼	048	0,24	0,34	0,42	0,48	0,59	0,68	0,8	0,9	1,1	1,3	
▼	▼	▼	▼	▼	065	0,33	0,46	0,56	0,65	0,80	0,92	1,0	1,2	1,5	1,8	
▼	▼	▼	▼	▼	095	0,48	0,67	0,82	0,95	1,2	1,3	1,5	1,8	2,1	2,6	
▼	▼	▼	▼	▼	102	0,60	0,85	1,0	1,20	1,5	1,7	1,9	2,2	2,7	3,3	
▼	▼	▼	▼	▼	105	0,8	1,1	1,3	1,50	1,8	2,1	2,4	2,8	3,4	4,1	

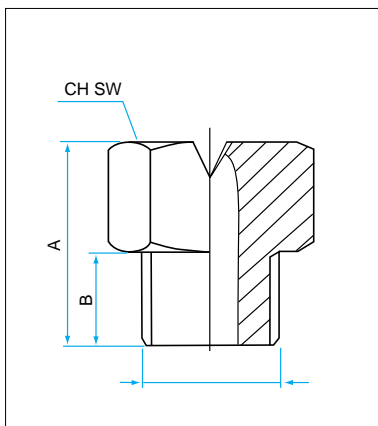

Tipo / Type OVK

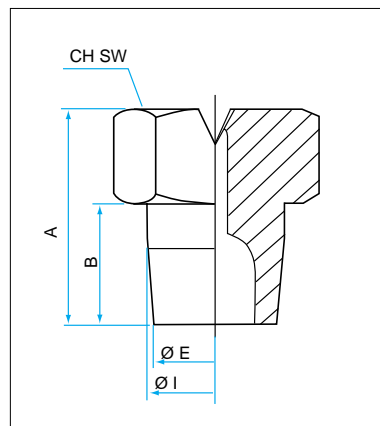

Tipo / Type OVKIR

DIMENSIONI - DIMENSIONS

	A	B	CH/SW	Ø I	Ø E
OVK	9	4	Es. 8	-	-
OVKIR	9,5	6	Es. 8	5,5	6,2